

# WORK WINCH™

## Integrated Tie-Down System

The Work Winch™ is installed on I.T.S.™ series racks after the entire rack has been assembled and installed. Work Winches can be installed with the winch on the right and handle on the left or it can be installed with the winch on the left and the handle on the right (a mirror image).

Slide 1 of the 2 large washers onto the winch shaft. Then install the PVC bearing, then insert the assembly halfway into the hole in the gusset (pick-up trucks) or bracket (vans). Orient the pawl (which is shaped like a dolphin) so that its nose is facing away from you and slide the 2" clevis pin through the pawl and into the small hole above the winch shaft. Slide the winch the rest of the way into the hole. Install the other large washer and then the cotter pin. Hold onto the winch take-up wheel and spread the cotter pin with a pair of pliers. The handle can be installed or left in a tool box or other accessible place. If it is to be installed, place the handle over the hex, install the smaller washer and then insert the linch pin and lock it. Engage the handle as shown below to prevent swinging and wear.

Insert 6" of the strap end into the slot in the mandrel and wind in a direction so that the top of the spool comes toward you (If the handle has been installed, disengage it from its upper position and let it hang freely so the hex can rotate within it). If the pawl is installed correctly, this is the only direction you will be able to turn the winch without lifting the pawl.

To secure a load, let the handle hang freely, lift the pawl and pull out enough strap to go over the load. For pick-up trucks, engage the hook on the underside of the 2 1/2" tall lip of the crossmember. For vans, wrap the hook end of the strap around the crossmember and then engage the hook on the strap, forming a loop around the crossmember. Take up the slack by rotating the hand wheel and tighten using the handle. Do not over tighten as the handle has been designed to slip on the hex if it is overstressed. **REMEMBER TO CHECK STRAP TENSION FREQUENTLY BECAUSE STRAPS STRETCH AND LOADS SETTLE.**

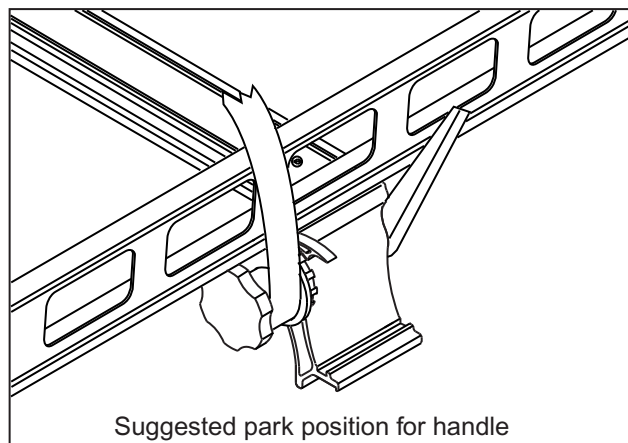

If handle is to be kept on winch shaft, engage as shown to prevent swinging and wear

The Work Winch™ has a rated capacity of 1200 lbs. This is the load the complete assembly will withstand before failure. It is recommended that the working load not exceed 400 lbs. (1/3 of the rated capacity).

Inspect strap and winch assembly before each use and replace if worn or damaged. Make sure that the cotter pin and washers are securely in place and that parts move freely. Keep at least 2 wraps of strap around mandrel. Keep strap away from sharp or hot surfaces. **CHECK TENSION FREQUENTLY - STRAPS STRETCH AND LOADS SETTLE.** No warranty is made about the suitability of this product for any purpose other than securing ladders. Keep cargo height within the side rails of the rack.

Work Winches™ can be installed from either the left side or the right side of I.T.S.™ series gussets and brackets. Pay careful attention to the orientation of both the pawl and the strap. The pawl looks like a dolphin and its nose faces away from you. The hook end of the strap should come up on the outside of the coil from underneath.

